

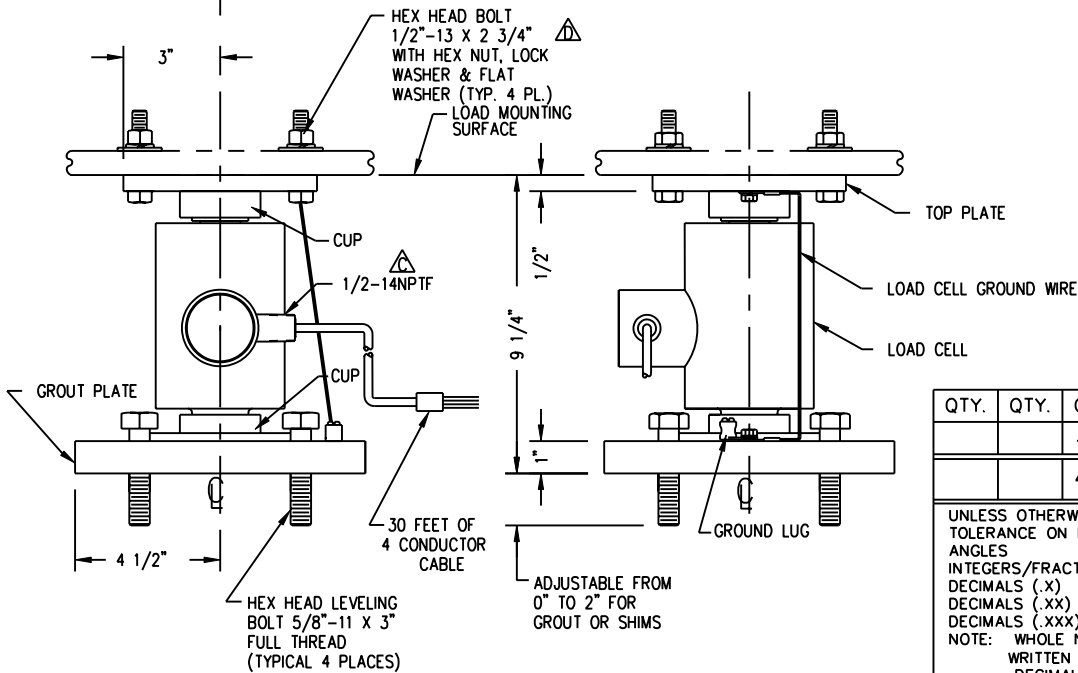

COLOR	FUNCTION
GREEN	+EXCITATION
BLACK	-EXCITATION
RED	+SIGNAL
WHITE	-SIGNAL
YELLOW	SHIELD



REVISION RECORD			
LTR	DESCRIPTION	DATE	BY
C	ADDED 1/2-14NPTF CALLOUT	3/29/95	14409 JAT/GG
D	REVISED APPEARANCE OF TOP PLATE HEX HEAD BOLT WAS 2 1/4" LONG	8/22/96	15191 JAT

**NOTES:**

1. **CAUTION:** DO NOT WELD ON WEIGHBRIDGE AND/OR RELATED STRUCTURE WHILE IN CONTACT WITH THIS LOAD CELL ASSEMBLY.
2. SEE CARDINAL DRAWING 3502-C008 FOR PROPER ELECTRICAL GROUNDING INFORMATION.
3. CAUTION MUST BE USED DURING INSTALLATION OF THE WEIGHBRIDGE TO PREVENT ANY SHOCK LOADING ON THE LOAD CELL ASSEMBLY.
4. THE LOAD CELL ASSEMBLY MUST BE LEVEL IN ALL DIRECTIONS.
5. THE LOAD CELL ASSEMBLY MUST BE RIGIDLY CHECKED. CONTACT THE CARDINAL SCALE ENGINEERING DEPARTMENT FOR INFORMATION ON PROPER SIZES OF LATERAL STABILIZERS AND BRACKETS.
6. THE LOAD CELL ASSEMBLY MUST BE INSTALLED PLUMB, LEVEL AND SQUARE. IF THE ASSEMBLY BECOMES "COCKED" RELIEVE PRESSURE ON TOP PLATE AND RE-ALIGN.
7. GROUTING IS RECOMMENDED. USE NON-SHRINKING GROUT (U.S. GROUT CORP. 5 STAR EPOXY OR EQUAL). THE GROUT SHOULD BE DISTRIBUTED BENEATH THE GROUT PLATE, NO VOIDS ALLOWED.

QTY.	QTY.	QTY.	ITEM	PART/DWG. NUMBER	DESCRIPTION	MATERIAL OR SOURCE	WT. EACH	
		-0A	ASSY					
	45.4	WT.	PARTS/MATERIAL LIST					
UNLESS OTHERWISE SPECIFIED TOLERANCE ON DIMENSIONS ARE:				 CARDINAL DETECTO FULLER WEIGHING SYSTEMS				
ANGLES				± 1/2°				
INTEGERS/FRACTIONS				± 1/16 IN.				
DECIMALS (.X)				± .03 IN.				
DECIMALS (.XX)				± .01 IN.				
DECIMALS (.XXX)				± .005 IN.				
NOTE: WHOLE NUMBERS MUST BE WRITTEN XX.000 TO INVOKE DECIMAL TOLERANCES.								
THIS DRAWING IS THE PROPERTY OF THE CARDINAL SCALE MFG. CO. AND SHALL NOT BE USED NOR REPRODUCED EITHER WHOLLY OR IN PART EXCEPT WITH WRITTEN AUTHORIZATION. ALL RIGHTS OF DESIGN OR INVENTION ARE RESERVED.				<b>TITLE</b> OUTLINE DRAWING: LOAD CELL SUPPORT ASSEMBLY 120,000 POUND CAPACITY				
SCALE 1/4" = 1"		DO NOT SCALE DRAWING		NEXT ASSEMBLY		REF. ENG. DWG. 2970-C102-0A		
DR. JAT		DATE 10/14/93		THIS DRAWING IS FOR CUSTOMER USE ONLY				
CH. RTB		DATE 1/28/94		MODEL 120K-SCA		SHEET 1 OF 1		
				DWG. NO. 3500-B112-0A		REV. D		